

Notes:
1. No dimensions to be scaled from this drawing.
2. All sizes to be checked on site and any discrepancies to be reported to the engineer.

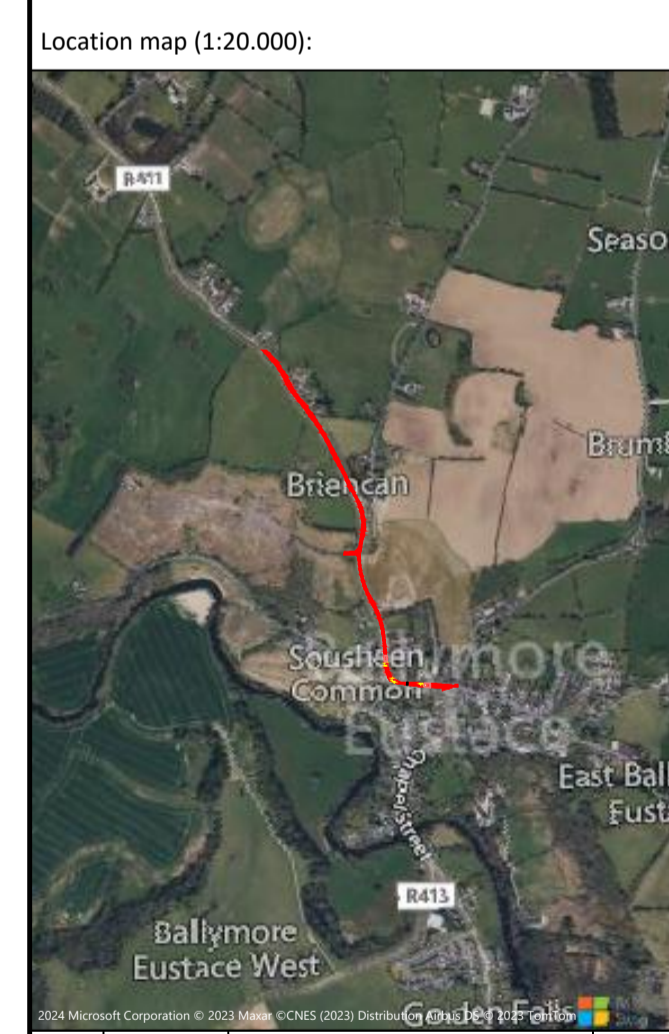
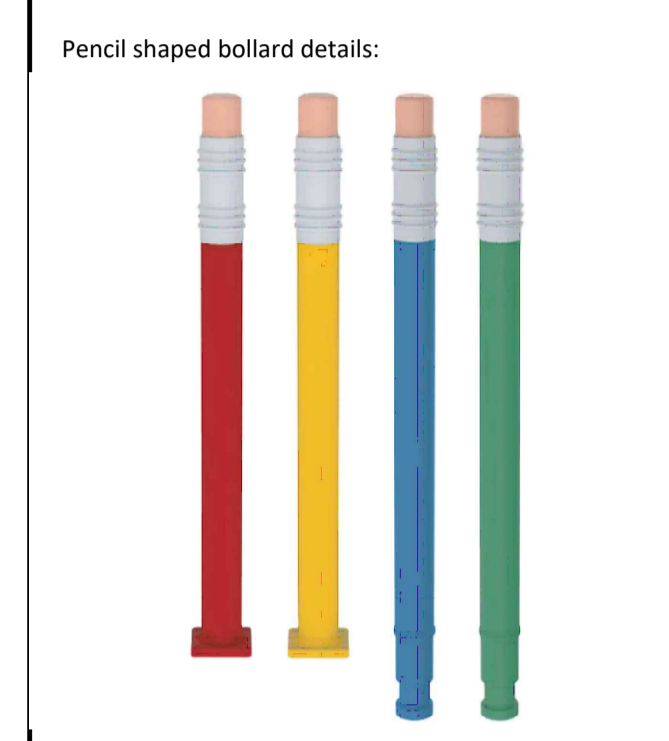
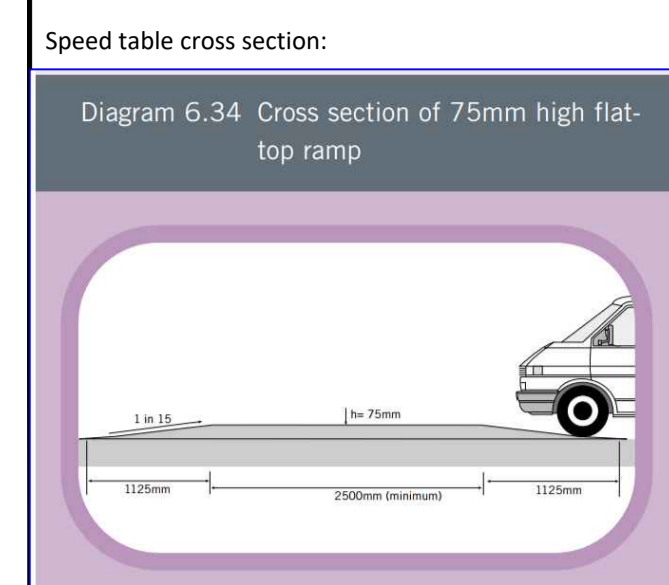

No.	Date	Issue / Revision	Chkd.

Project:
Proposed Traffic Calming,
Naas Road (R411)
Ballymore Eustace,
Co. Kildare

Dwg. Title:
Proposed Layout Plan

Dwg. No. E3985	O.S. Ref. No.: 3723-A	Rev. *	Map: [Scale]
Date: 30/01/2024	Scale: 1:1,000 (A1)	Approved: M.K.	
Drawn: A.B.M.			

Roads Transportation and Public Safety Dept.
Roads Design Office
Senior Engineer - Stephen Deegan- BE GradDipPSHW MEng

Kildare County Council, Comhairle Chontae Cill Dara
Áras Chill Dara, Derry Park, Naas, Co. Kildare
T:+353-45-980424 F:+353-45-980420 E:roads@kildarecoco.ie